

INSTALLATION INSTRUCTIONS FLEXIBLE TUBING SERVICE HEAD ADAPTERS

IMPORTANT

For use on:

Polyethylene (PE) gas pipe meeting the requirements of ASTM D 2513

Pressure Rating: Designed to meet or exceed pressure rating of PE pipe per 49 CFR Part 192 and ASTM D 2513

Operating Temperature: -20 to 140° F

Material: Carbon Steel

1. VERIFY THAT THE ADAPTER COUPLING IS THE CORRECT SIZE FOR THE POLYETHYLENE (PE) PIPE. VERIFY THE SDR (OR WALL THICKNESS) OF THE PIPE MATCHES THE SDR (OR WALL THICKNESS) STAMPED ON END OF STIFFENER.
2. INSTALL PE PIPE THRU RISER, LEAVING 10" MINIMUM EXTENDING ABOVE RISER (FIG 1).
3. CUT PE PIPE END SQUARE, DEBURR INSIDE AND OUTSIDE, CLEAN THOROUGHLY TO ASSURE THERE IS NO DIRT, GREASE, OIL, ETC. ON ASSEMBLY AREA OF PIPE.
4. INSTALL COMPRESSION NUT ONTO THE FLEX RISER CASING, HAND TIGHT (FIG 2).
5. SLIDE SEAL RING OVER PE PIPE AND INTO THE COMPRESSION NUT (FIG 3).
6. MARK 1 1/4" LG STAB LENGTH ON PE PIPE (FIG 3).
7. INSERT PE PIPE INTO ADAPTER COUPLING. LINE MARKED FOR STAB LENGTH SHOULD BE NO MORE THAN 1/4" FROM END OF ADAPTER COUPLING, IF NOT, REASSEMBLE (FIG 4).
8. PUSH ENTIRE ASSEMBLY TO COMPRESSION NUT.
9. TIGHTEN ADAPTER COUPLING UNTIL IT BOTTOMS AGAINST SHOULDER OF COMPRESSION NUT (FIG 5).
10. TO ASSURE PROPER ASSEMBLY AND TO COMPLY WITH 49 CFR 192 SUBPART J—TEST REQUIREMENTS, THE JOINT SHALL BE LEAK TESTED.

NOTE: TO PREVENT INADVERTENT PULL-OUT OF THE PE PIPE DURING THE ASSEMBLY PROCESS, COMPLETE STEP #9 IMMEDIATELY AFTER STEP #8, WITHOUT DELAY AND ENSURE WORK IS NOT BEING PERFORMED ON THE FREE END OF THE PE PIPE.

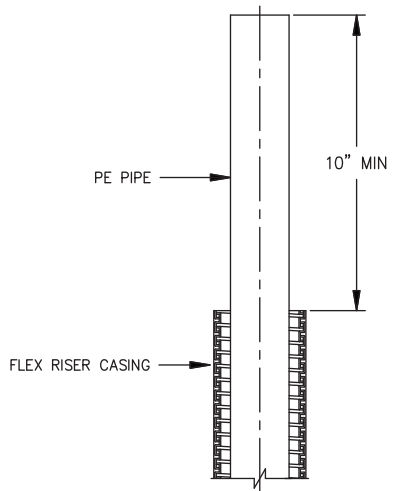

FIG. 1

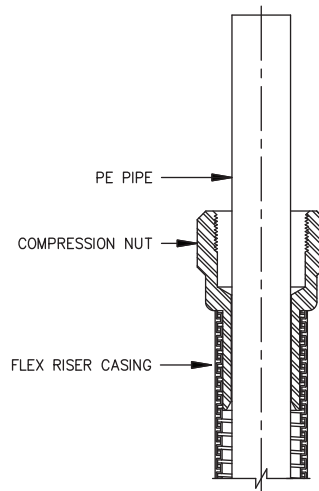

FIG. 2

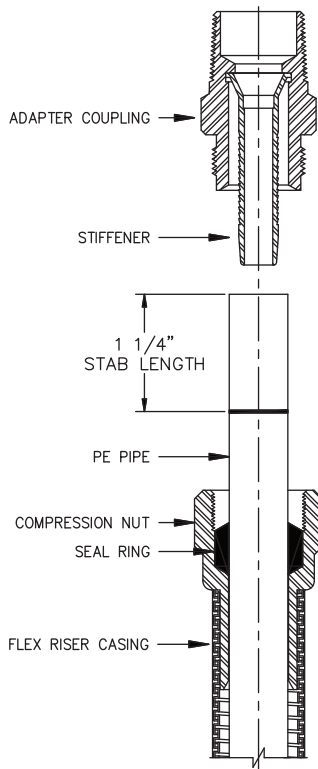

FIG. 3

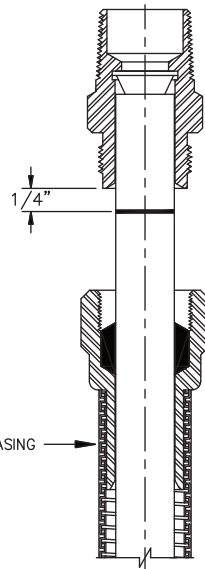

FIG. 4

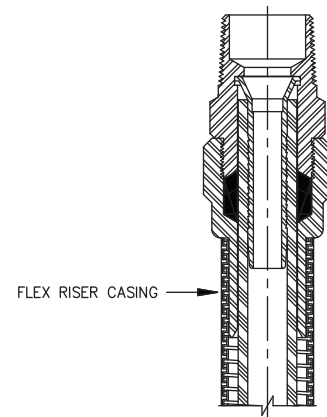

FIG. 5